

Pole Saw 750W

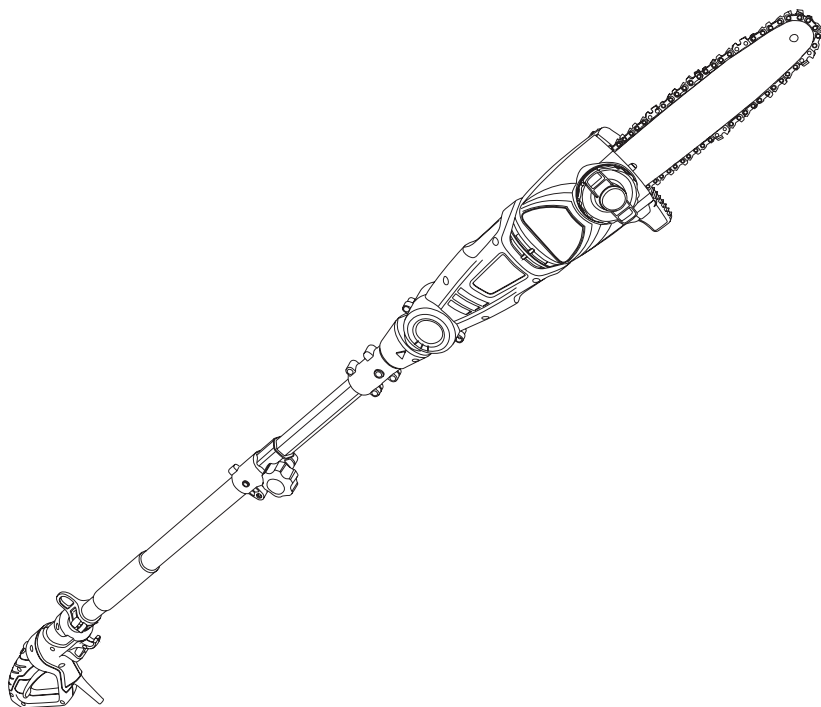

ORIGINAL INSTRUCTIONS MPS750S-2

EAN: 3663602627661 / 3663602627685

TTPS750

EAN: 5063022106032 / 5063022106384

Original Instructions_MNL_MPS750S-2 / TTPS750_GB_V30323

MAND1_2223



WARNING: Read the instructions before using the product!

Let's get started...

These instructions are for your safety. Please read through them thoroughly before use and retain them for future reference.



Getting **started...** **02**

Safety information **03**

Your product **16**

Before you start **17**



In more detail... **29**

Product functions **30**

Operation **32**

Care and **maintenance** **37**

Troubleshooting **44**

Recycling and **disposal** **45**

Technical specifications **46**

Guarantee **47**

Declaration of **conformity** **50**

Safety warnings

**IMPORTANT****READ CAREFULLY BEFORE USE.
KEEP FOR FUTURE REFERENCE.**

General Power Tool Safety Warnings



WARNING! Read all safety warnings and all instructions. Failure to follow the warnings and instructions may result in electric shock, fire and/or serious injury. Save all warnings and instructions for future reference.

The term “power tool” in the warnings refers to your mains-operated (corded) power tool or battery-operated (cordless) power tool.

Work area safety

1. **Keep work area clean and well lit.** Cluttered or dark areas invite accidents.
2. **Do not operate power tools in explosive atmospheres, such as in the presence of flammable liquids, gases or dust.** Power tools create sparks which may ignite the dust or fumes.
3. **Keep children and bystanders away while operating a power tool.** Distractions can cause you to lose control.

Electrical safety

1. **Power tool plugs must match the outlet. Never modify the plug in any way. Do not use any adapter plugs with earthed (grounded) power tools.** Unmodified plugs and matching outlets will reduce risk of electric shock.

2. **Avoid body contact with earthed or grounded surfaces, such as pipes, radiators, ranges and refrigerators.** There is an increased risk of electric shock if your body is earthed or grounded.
3. **Do not expose power tools to rain or wet conditions.** Water entering a power tool will increase the risk of electric shock.
4. **Do not abuse the cord. Never use the cord for carrying, pulling or unplugging the power tool. Keep cord away from heat, oil, sharp edges or moving parts.** Damaged or entangled cords increase the risk of electric shock.
5. **When operating a power tool outdoors, use an extension cord suitable for outdoor use.** Use of a cord suitable for outdoor use reduces the risk of electric shock.
6. **If operating a power tool in a damp location is unavoidable, use a residual current device (RCD) protected supply.** Use of an RCD reduces the risk of electric shock.
7. **If the supply cord is damaged, it must be replaced by the manufacturer, its service agent or similarly qualified persons in order to avoid a hazard.**

Personal safety

1. **Stay alert, watch what you are doing and use common sense when operating a power tool. Do not use a power tool while you are tired or under the influence of drugs, alcohol or medication.** A moment of inattention while operating power tools may result in serious personal injury.

2. **Use personal protective equipment. Always wear eye protection.** Protective equipment such as dust mask, non-skid safety shoes, hard hat, or hearing protection used for appropriate conditions will reduce personal injuries.
3. **Prevent unintentional starting. Ensure the switch is in the off-position before connecting to power source and/or battery pack, picking up or carrying the tool.** Carrying power tools with your finger on the switch or energising power tools that have the switch on invites accidents.
4. **Remove any adjusting key or wrench before turning the power tool on.** A wrench or a key left attached to a rotating part of the power tool may result in personal injury.
5. **Do not overreach. Keep proper footing and balance at all times.** This enables better control of the power tool in unexpected situations.
6. **Dress properly. Do not wear loose clothing or jewellery. Keep your hair, clothing and gloves away from moving parts.** Loose clothes, jewellery or long hair can be caught in moving parts.
7. **If devices are provided for the connection of dust extraction and collection facilities, ensure these are connected and properly used.** Use of dust collection can reduce dust-related hazards.

Power tool use and care

1. **Do not force the power tool. Use the correct power tool for your application.** The correct power tool will do the job better and safer at the rate for which it was designed.

2. **Do not use the power tool if the switch does not turn it on and off.** Any power tool that cannot be controlled with the switch is dangerous and must be repaired.
3. **Disconnect the plug from the power source and I or the battery pack from the power tool before making any adjustments, changing accessories, or storing power tools.** Such preventive safety measures reduce the risk of starting the power tool accidentally.
4. **Store idle power tools out of the reach of children and do not allow persons unfamiliar with the power tool or these instructions to operate the power tool.** Power tools are dangerous in the hands of untrained users.
5. **Maintain power tools. Check for misalignment or binding of moving parts, breakage of parts and any other condition that may affect the power tool's operation. If damaged, have the power tool repaired before use.** Many accidents are caused by poorly maintained power tools.
6. **Keep cutting tools sharp and clean.** Properly maintained cutting tools with sharp cutting edges are less likely to bind and are easier to control.
7. **Use the power tool, accessories and tool bits etc. in accordance with these instructions, taking into account the working conditions and the work to be performed.** Use of the power tool for operations different from those intended could result in a hazardous situation.

Service

1. **Have your power tools serviced by a qualified repair person using only identical replacement parts.** This will ensure that safety of the power tool is maintained.

Pruner safety warnings

1. **Interrupt your work when you feel tired or exhausted. Make regular breaks to regenerate.** A moment of inattention while operating the product may result in serious personal injury.
2. **Keep all parts of the body away from the saw chain. Do not remove cut material or hold material to be cut when saw chain is moving. Make sure the switch is off when clearing jammed material.** A moment of inattention while operating the product may result in serious personal injury.
3. **Hold the product by insulated gripping surfaces only, because the saw chain may contact hidden wiring or its own cord.** Saw chains contacting a “live” wire may make exposed metal parts of the product “live” and could give the operator an electric shock.
4. **Keep cable away from cutting area.** During operation the cable may be hidden in shrubs and can be accidentally cut by the blade.
5. **Keep all parts of the body away from the saw chain when the product is operating. Before you start the product, make sure the saw chain is not contacting anything.** A moment of inattention while operating products may cause entanglement of your clothing or body with the saw chain.

6. **Always hold the product with both hands on the handle and soft grip.** Holding the product with only one hand or on parts not intended for that increases the risk of personal injury and should never be done.
7. **Wear safety glasses and hearing protection. Further protective equipment for head, hands, legs and feet is recommended.** Adequate protective clothing will reduce personal injury by flying debris or accidental contact with the saw chain.
8. **Do not operate a product in a tree.** Operation of a product while up in a tree may result in personal injury.
9. **Always keep proper footing and operate the product only when standing on fixed, secure and level surface.** Slippery or unstable surfaces such as ladders may cause a loss of balance or control of the product.
10. **When cutting a limb that is under tension be alert for spring back.** When the tension in the wood fibres is released the spring loaded limb may strike the operator and/or throw the product out of control.
11. **Use extreme caution when cutting brush and saplings.** The slender material may catch the saw chain and be whipped toward you or pull you off balance.
12. **Carry the product by the soft grip with the product switched off and away from your body. When transporting or storing the product always fit the guide bar cover.** Proper handling of the product will reduce the likelihood of accidental contact with the moving saw chain.

13. **Follow instructions for lubricating, chain tensioning and changing accessories.** Improperly tensioned or lubricated chain may either break or increase the chance for kickback.
14. **Keep handles dry, clean, and free from oil and grease.** Greasy, oily handles are slippery causing loss of control.
15. **Cut wood only. Do not use product for purposes not intended. For example: do not use product for cutting plastic, masonry or non-wood building materials.** Use of the product for operations different than intended could result in a hazardous situation.
16. **Pay attention to national and local regulations.** National and local regulations may restrict the use of this product.
17. Only use replacement guide bars and saw chains specified by the manufacturer or equivalent replacements. Using non-approved cutting attachments can result in personal injuries and damage to property.
18. Before using the product and after any impact or dropping, check for signs of wear or damage and repair as necessary.
19. Never remove or modify any guard or safety component. Ensure that guards and other safety components necessary for machine operation are in position, in good working condition and properly maintained to avoid injuries.
20. Training of all operation is necessary for first-time and inexperienced operator.
21. Remove branches in section.
22. Use the harness provided.

Causes and operator prevention of kickback

Kickback may occur when the nose or tip of the guide bar touches an object, or when the wood closes in and pinches the saw chain in the cut.

Tip contact in some cases may cause a sudden reverse reaction, kicking the guide bar up and back towards the operator.

Pinching the saw chain along the top of the guide bar may push the guide bar rapidly back towards the operator.

Either of these reactions may cause you to lose control of the saw which could result in serious personal injury. Do not rely exclusively upon the safety devices built into your saw. As a product user, you should take several steps to keep your cutting jobs free from accident or injury.

Kickback is the result of tool misuse and/or incorrect operating procedures or conditions and can be avoided by taking proper precautions as given below:

1. **Maintain a firm grip, with thumbs and fingers encircling the product handles, with both hands on the saw and position your body and arm to allow you to resist kickback forces.** Kickback forces can be controlled by the operator, if proper precautions are taken. Do not let go of the product.
2. **Do not overreach.** This helps prevent unintended tip contact and enables better control of the product in unexpected situations.
3. **Only use replacement bars and chains specified by the manufacturer.** Incorrect replacement bars and chains may cause chain breakage and/or kickback.

4. **Follow the manufacturer's sharpening and maintenance instructions for the saw chain.** Decreasing the depth gauge height can lead to increased kickback.

Vibration and noise reduction

To reduce the impact of noise and vibration emission, limit the time of operation, use low-vibration and low- noise operating modes as well as wear personal protective equipment.

Take the following points into account to minimize the vibration and noise exposure risks:

1. Only use the product as intended by its design and these instructions.
2. Ensure that the product is in good condition and well maintained.
3. Use correct application tools for the product and ensure they in good condition.
4. Keep tight grip on the handles/grip surface.
5. Maintain this product in accordance with these instructions and keep it well lubricated (where appropriate).
6. Plan your work schedule to spread any high vibration tool use across a longer period of time.

The European Physical Agents (Vibration) Directive has been brought in to help reduce hand arm vibration syndrome injuries to users of product's with vibration emission. The directive requires manufacturers and suppliers to provide indicative vibration test results to enable users to make informed decisions as to the period of time a product can be used safely on a daily basis and the choice of tool. Further advice can be found at www.hse.gov.uk

Emergency

Familiarise yourself with the use of this product by means of this instruction manual. Memorise the safety directions and follow them to the letter. This will help to prevent risks and hazards.

1. **Always be alert when using this product, so that you can recognise and handle risks early.** Fast intervention can prevent serious injury and damage to property.
2. **Switch off and disconnect from the power supply if there are malfunctions.** Have the product checked by a qualified professional and repaired, if necessary, before you operate it again.

Residual risks

Even if you are operating this product in accordance with all the safety requirements, potential risks of injury and damage remain. The following dangers can arise in connection with the structure and design of this product:

1. Health defects resulting from vibration emission if the product is being used over long periods of time or not adequately managed and properly maintained.
2. Injuries and damage to property due to broken accessories or the sudden impact of hidden objects during use.
3. Danger of injury and property damage caused by flying objects.

4. Prolonged use of this product expose the operator to vibrations and may produce 'whitefinger' disease. In order to reduce the risk, please wear gloves and keep your hands warm. If any of the 'whitefinger' symptoms appear, seek medical advice immediately 'Whitefinger' symptoms include: numbness, loss of feeling, tingling, pricking, pain, loss of strength, changes in skin colour or condition. These symptoms normally appear in the fingers, hands or wrists. The risk increases at low temperatures.



WARNING! This product produces an electromagnetic field during operation! This field may under some circumstances interfere with active or passive medical implants! To reduce the risk of serious or fatal injury, we recommend persons with medical implants to consult their doctor and the medical implant manufacturer before operating this product!

Symbols

On the product, the rating label and within these instructions you will find among others the following symbols and abbreviations. Familiarise yourself with them to reduce hazards like personal injuries and damage to property.

V ~	Volt, (alternating voltage)	min ⁻¹	Per minute
W	Watt	mm	Millimetre
Hz	Hertz	kg	Kilogram
l	Litre	m/s ²	Metres per second squared
cm ³	Cubic centimetre	dB(A)	Decibel (A-rated)
yyWxx	Manufacturing date code: year of manufacturing (20yy) and week of manufacturing (Wxx).		



Read the instruction manual.



Caution / Warning.



Wear hearing protection!
Wear eye protection!
Wear respiratory protection!



Wear protective gloves!



Wear slip-resistant, sturdy footwear!



Wear safety helmet!



Wear face protection!



Wear tight-fitted protective clothes.



Warning! Danger from overhead electric-power lines! Keep at least 10 m distance.



Switch the product off and disconnect it from the power supply before assembly, cleaning, adjustments, maintenance, storage and transportation.



Remove plug from the mains immediately if the power cord/extension cord is damaged or cut.



Objects thrown by the product could hit the user or other bystanders. Always ensure that other people and pets remain at a safe distance from the product when it is in operation. In general, children must not come near the area where the product is. Minimum distance 15m.



Kickback! Tip contact may cause the guide bar to move suddenly upward and backwards what may cause serious injury to user.



Contact of the guide bar tip with any object should be avoided.



Always use the product with two hands. Do not use one handed when operating the product.



Do not use in rain or wet conditions.



Guaranteed sound power level value in dB.



Chain oil fill



Correct direction of cutting-teeth



Cutting of fingers or hand.



Danger of falling objects.



This product is of protection class II. That means it is equipped with enhanced or double insulation.



This marking indicates that this product should not be disposed with other household wastes.

To prevent possible harm to the environment or human health from uncontrolled waste disposal, recycle it responsibly to promote the sustainable reuse of material resources.



The product complies with the applicable Your product European directives and an evaluation method of conformity for these directives was done.



UK Conformity Assessed.

MPS750S-2 / TTPS750 (M_Brand Name; PS_Pole Saw)

Your product

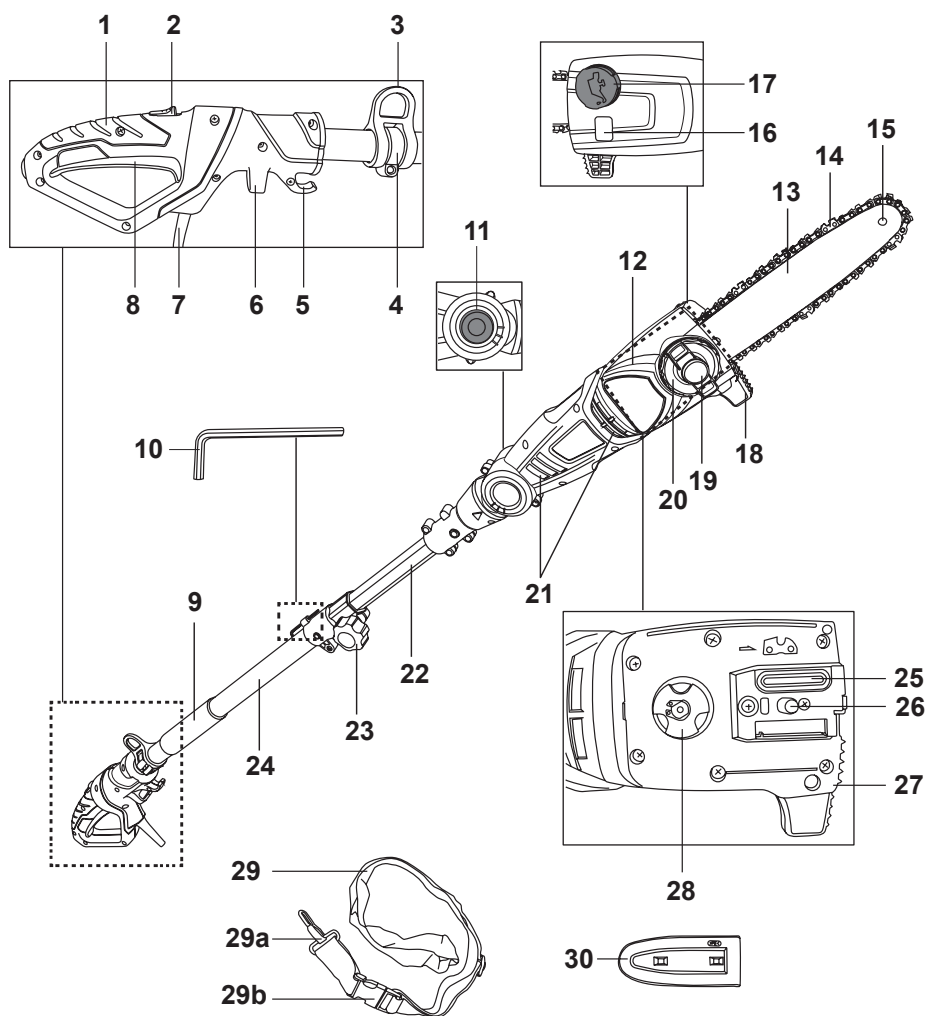

- | | |
|------------------------|----------------------------|
| 1. Rear handle | 7. Power cord with plug |
| 2. Lock-off button | 8. On/off switch |
| 3. Loop | 9. Gripping surface |
| 4. Loop retainer | 10. Hex key 4mm |
| 5. Cable strain relief | 11. Angle adjusting button |
| 6. Hole | 12. Side cover |

- | | |
|----------------------|-------------------------|
| 13. Guide bar | 23. Locking knob |
| 14. Saw chain | 24. Pole |
| 15. Sprocket wheel | 25. Oiling port |
| 16. Oil level window | 26. Mounting bolt |
| 17. Oil tank cap | 27. Anti-slip serration |
| 18. Park stand | 28. Drive sprocket |
| 19. Locking wheel | 29. Harness |
| 20. Tension wheel | a. Clip |
| 21. Air vents | b. Buckle |
| 22. Pole extension | 30. Guide bar cover |

Unpacking

1. Unpack all parts and lay them on a flat, stable surface.
2. Remove all packing materials and shipping devices if applicable.
3. Make sure the delivery contents are complete and free of any damage. If you find that parts are missing or show damage do not use the product but contact your dealer. Using an incomplete or damaged product represents a hazard to people and property.
4. Ensure that you have all the accessories and tools needed for assembly and operation. This also includes suitable personal protective equipment.

You will need

(items not supplied)

Lubrication oil
 Sharpening set
 Suitable personal protective equipment

(items supplied)

Hex key 4mm x1

Assembly



WARNING! The product must be fully assembled before operation! Do not use a product that is only partly assembled or assembled with damaged parts!



Follow the assembly instructions step-by-step and use the pictures provided as a visual guide to easily assemble the product!

Do not connect the product to power supply before it is completely assembled!

Always wear gloves during assembly!

Motor unit assembly

1. Place the product (the rear part) and motor unit on a flat stable surface with the side cover (12) facing upwards.
2. Turn the pre-assembled screw anticlockwise by using the hex key (10), and remove it together with the nut, keep them on hand. (Fig. 1)

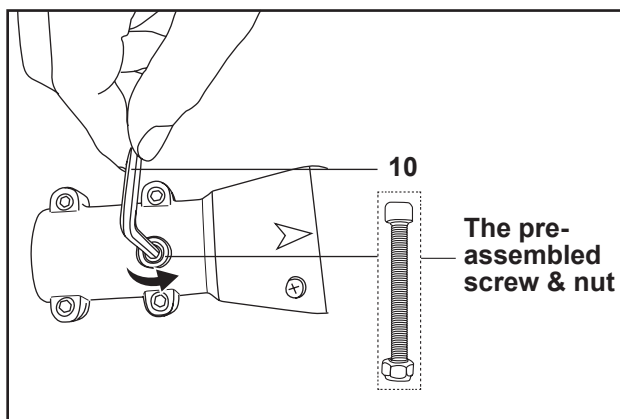

Fig. 1

3. Loosen the locking knob (23) by turning it anticlockwise, pull the pole extension (22) out. Caution as pole may retract quickly. Afterwards tighten the locking knob (23) by turning it clockwise. (Fig. 2)

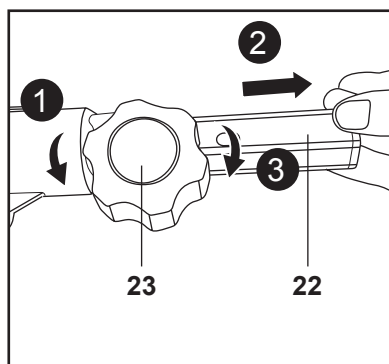

Fig. 2

- Align the pole extension (22) to the motor unit and insert it all the way to the stop. Secure the connection with the screw and nut. (Fig. 3)

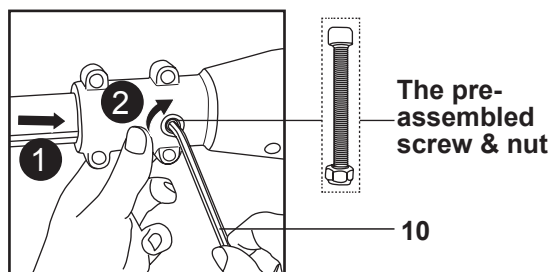

Fig. 3

- Tighten 4 pre-assembled screws on the motor unit by using the provided hex key (10). (Fig. 4)

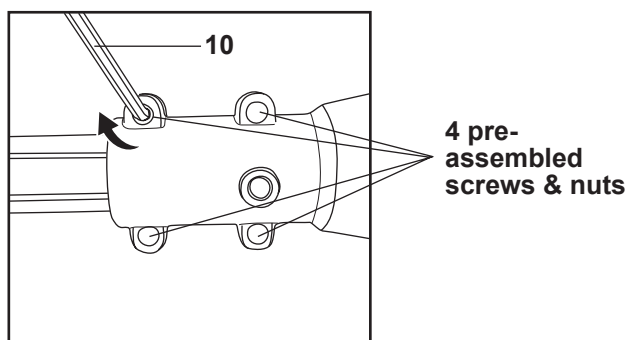



Fig. 4

Saw chain and guide bar

- Use only a guide bar (13) and saw chain (14) according to the technical data of the pole saw.
- Place the product on a suitable flat surface with the side cover (12) facing upwards.
- Unscrew the locking wheel (19) in direction  and then remove it together with the side cove (12). (Fig.5)

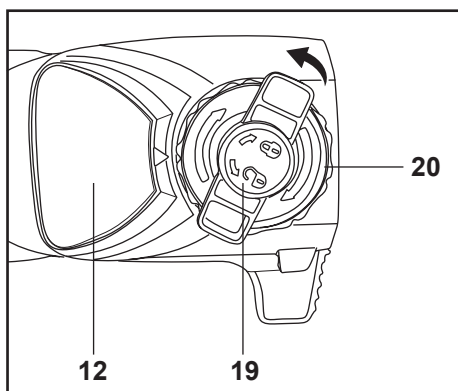

Fig. 5

4. Spread the saw chain (14) out with the cutting edges of the chain pointing in the direction of rotation.

Slide the saw chain (14) into the groove around the guide bar (13). Ensure saw chain (14) is installed in correct direction of rotation. (Fig. 6)

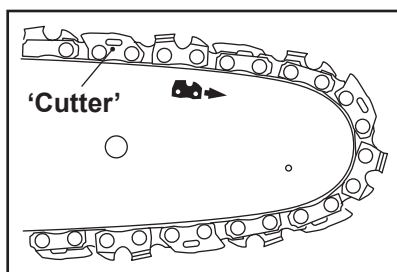

Fig. 6



WARNING! The direction of the saw chain 'cutters' must be same as indicated by the symbol and arrow on the guide bar!

5. Align saw chain (14) and the guide bar (13) assembly with the drive sprocket (28) and the mounting bolt (26). Lay the saw chain (14) around the drive sprocket (28) and then lower the guide bar (13) to install it to the mounting bolt (26). (Fig.7)

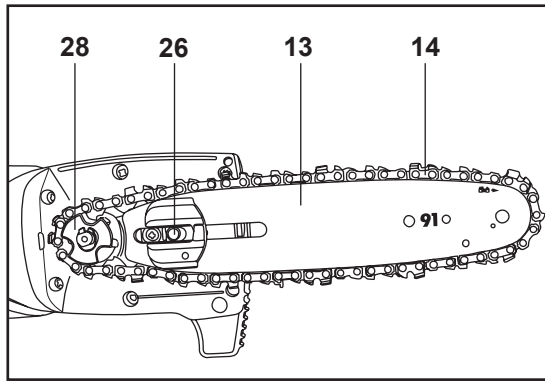

Fig. 7

6. The saw chain movement is as indicated by the arrow (Fig.8). Make sure the saw chain (14) is properly placed over the sprocket wheel (15) of the guide bar (13). (Fig.8)

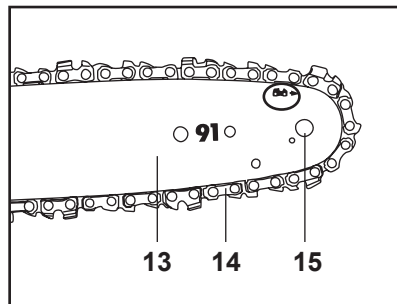
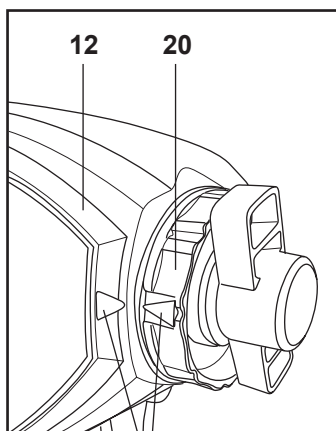

Fig. 8

7. Please make sure the tension wheel (20) is in the position as shown in Fig.9, or else rotate it anticlockwise to make the mark on the side cover (12) be aligned with the mark on the tension wheel (20). (Fig.9)



Two marks be aligned

Fig. 9

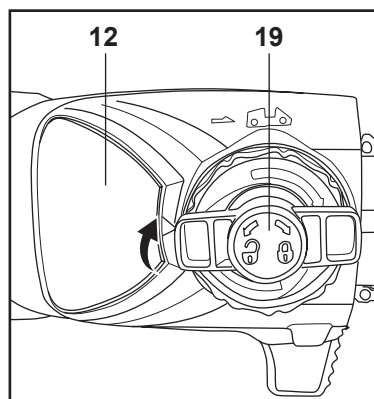

Fig. 10

8. Refit the cover (12), fit the rear of cover then front, ensure pin is located in position. Slightly tighten the locking wheel (19) (Fig. 10). Do not tighten the locking wheel (19) completely, saw chain tensioning is required first.



NOTE: The saw chain (14) has not yet been tensioned. Tension the chain as described under "Saw chain tensioning". After operating the product for approx. 1 hour, adjust the chain tension again.

Saw chain tensioning

Always check the saw chain tension before use, after the first cuts and regularly during use, approx. every five cuts. Upon initial operation, new chains can lengthen considerably. This is normal during the break-in period and the interval between future adjustments will lengthen quickly.



WARNING! Disconnect the product from the power supply before adjusting saw chain tension!



The cutting edges of the saw chain are sharp! Always wear protective gloves when handling chain!



Always maintain proper chain tension! A loose chain increases the risk of kickback! A loose chain may jump out of the guide bar groove! This may injure the operator and damage the chain! A loose chain will cause rapid wear to the chain, guide bar and sprocket!

Tensioning the chain too tightly will overload the motor and cause damage, and insufficient tension can cause chain derailing, whereas a correctly tightened chain provides the best cutting characteristics and prolonged working life! The chain life mainly depends upon sufficient lubrication and correct tensioning!



NOTE: The chain tension can not be adjusted with the tension wheel (19) tightened - it must be loosened first.

1. Place the product on a suitable flat surface with the side cover (12) facing upwards.
2. Check the chain tension using one hand to lift the saw chain (14) against the weight of the product. The correct chain tension is achieved when the saw chain can be lifted by approximately 2 - 4 mm from the guide bar (13) in the centre (Fig.11, 12).

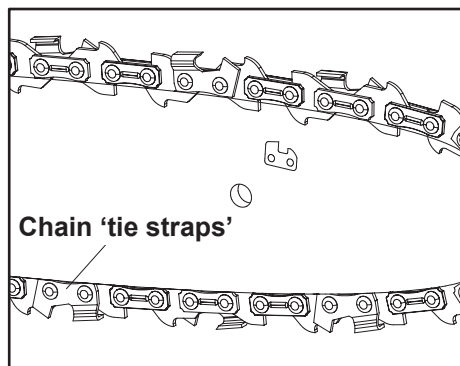

Fig. 11

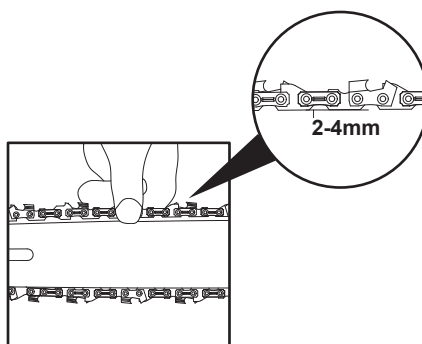

Fig. 12

3. Adjust the tension if you find that the chain saw (14) is too loose or tight.
4. Loosen the locking wheel (19), then rotate the tension wheel (20) anticlockwise or clockwise until the chain "tie straps" are just touching the bottom edge of the guide bar (12), hold it in the position.

5. Pull the saw chain (14) along the top of the guide bar (13) by gloved hand from one end to the other, several times. The saw chain (14) should feel tight but still move freely. If the chain tension has been adjusted, re-check tension in accordance with Step 2.
6. After the adjustment, re-tighten the locking wheel (19).

Chain lubrication



WARNING! The product is not filled with chain oil. It is essential to fill the product with chain oil before using it! Never operate the product without chain oil as this will result in extensive damage to the product!

Operating the saw chain dry or with too little chain oil will decrease cutting efficiency, shorten the product life span and cause rapid wear to the saw chain and guide bar from overheating!

Insufficient chain oil is evident by smoke or bar discoloration! Adequate lubrication of the saw chain during cutting operations is essential to minimise friction with the guide bar!

1. Place the product on a stable, level surface with the oil tank cap (17) facing upward. We recommend laying a non-flammable sheet under the product.
2. Unscrew and remove the oil tank cap (17) (Fig. 13).

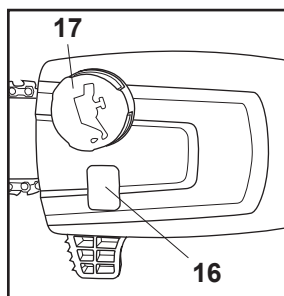

Fig. 13

3. Fill suitable lubricant into the tank using an oil funnel fitted with a filter to avoid debris entering the tank. Do not overfill and leave approximately 5 mm of space between the top of the oil and the inside edge of the tank to allow for expansion (Fig. 14).



NOTE: In summer use SAE #30; in winter, or if the trees have excessive sap, use SAE #10.

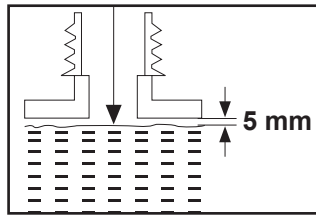

Fig. 14



NOTE: Towards the end of the season, it is advisable to put only as much lubricant in the tank as you need for each cut, so that it is completely used up before you store the product.

4. Check the oil level window (16) prior to start-up and regularly during operation. Refill oil when the oil level is close to the bottom of the oil level window (16) (Fig. 13).
5. Wipe up spilled lubricant with a soft cloth and refit the oil tank cap (17).



NOTE: Always dispose of lubricant, used oil and objects contaminated with them in accordance with local regulations.

Checking



NOTE: Perform the following test before operating your product.

This product is equipped with an automatic oiling system. The oiling system automatically delivers the proper amount of oil to the bar and chain.

Checking the lubrication requires starting the product. Before checking, the product must be fully assembled and all instructions must have been read.

1. Make sure the guide bar (13) and the saw chain (14) are in place when you check the oil delivery.
2. Start the product; keep it running at no load and check if the chain oil is delivered as shown in the figure (Fig.15,16).

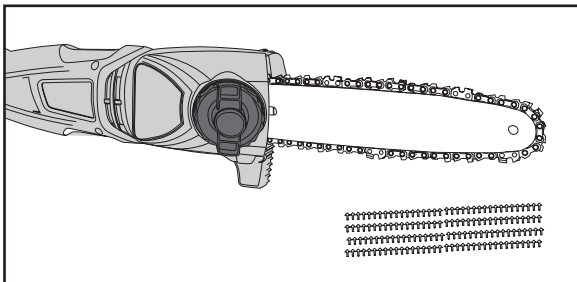

Fig. 15

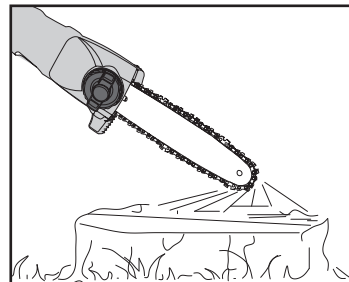

Fig. 16

Harness

The harness (29) helps the operator carry this product.



WARNING! Always attach the product to the harness. Do not carry it only with your hands!

1. Attach the clip (29a) of the harness (29) to the loop (3) on the pole (24) (Fig. 17).
2. Place the harness (29) so that it runs over your right shoulder. The securing clip must be located at the right hip (Fig.18).

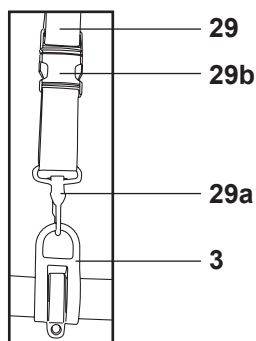

Fig. 17

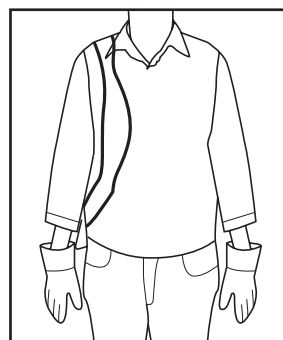

Fig. 18

3. Open the clip (29a) to remove the harness from the loop (3).
4. Open the buckle (29b) to quickly release the harness (29).
5. If required, set the loop retainer (4) on a proper position for comfort and easy control. Loosen the screw and move the loop retainer (4) back and forward along the pole (24). It's better to locate the loop retainer (4) within the range about 30cm from the gripping surface (9). After adjustment, re-tighten the screw. (Fig.19)

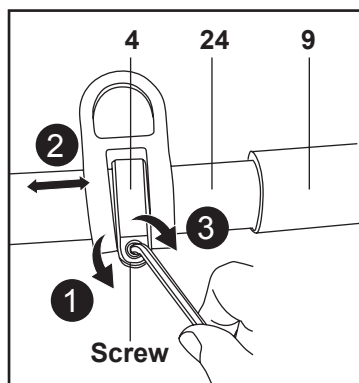

Fig. 19

Connection to the power supply (for UK only)



WARNING! Always use a residual current supply (RCD) protected supply. If an extension cord is used, make sure the extension cord is specifically designed for outdoor use and not lighter than H05VV-F or H05RN-F, 2 x 1.0mm² and max 75m.

1. Make sure the on/off switch (8) is in its off position.
2. Connect the power plug to a suitable power source.
3. Now your product is ready for use.

Connection to the power supply (not for UK)

For safety reasons the product is equipped with a short power cord (7). Do not connect the product directly to the power supply using this power cord. A proper extension cord is required for operation. Observe the technical requirements for this product when purchasing an extension cord.



WARNING! For your safety, it is required that the plug attached to this product is always connected to an extension cord! The extension cord must be suitable for outdoor use with sockets protected against water splashing! Ensure the extension cord is of the proper size and type for your product ($\geq 1.0\text{mm}^2$)!

The extension cord must always be used with the cable strain relief! Do not use the product without an extension cord connected! Always use a residual current supply (RCD) protected supply!

1. Make sure the on/off switch (8) is in its off position.
2. Double the extension cord back about a foot from the end, lead the loop through the hole (6) and hook the loop over the cable strain relief (5), gently tug on the cord to ensure that it is firmly secured. (Fig. 20, 21).

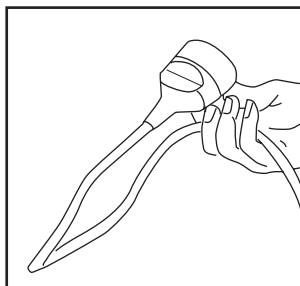

Fig. 20

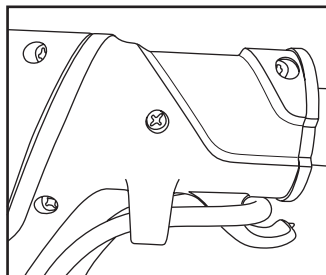

Fig. 21

3. Connect the power cord (7) to the socket of the extension cord. (Fig. 22)

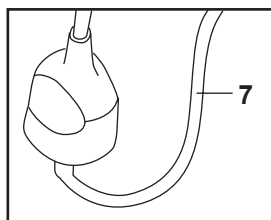

Fig. 22

4. Make sure not to press the on/off switch (8).
5. Connect the plug of the extension cord to a suitable power source.



WARNING! Check the voltage! The voltage must comply with the information on the rating label!

6. Your product is now ready to be used.



In more detail...

Product functions	30
Operation	32
Care and maintenance	37
Troubleshooting	44
Recycling and disposal	45
Technical specifications	46
Guarantee	47
Declaration of conformity	50

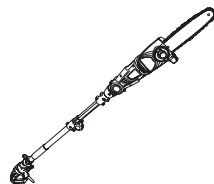

Intended use

This pole saw MPS750S-2 / TTPS750 is designated with a rated input of 750 Watts. The product is intended for cutting limbs with a thickness of max. 180 mm. It must not be used for cutting other materials, such as plastic, stone, metal or wood that contains foreign objects. The product may only be used with the guide bar/saw chain combination stated in these instructions. It is not permitted to use other types or sizes.

This product should not be used outside of domestic areas. This product is intended for private domestic use only, not for any commercial trade use. It must not be used for any purposes other than those described.

Adjusting pole length

1. Loosen the locking knob (23) by turning in a counter-clockwise direction and adjust the pole extension (22) to the required length. (Fig. 23)
2. Tighten the locking knob (23) by turning in a clockwise direction. (Fig. 23)

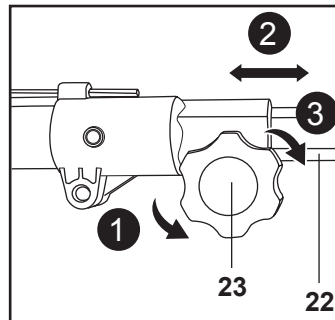

Fig. 23

Switching on/off

1. Ensure the saw chain (14) does not come into contact with anything before starting the product.
2. Grip the product with both hands, your left hand holding the gripping surface (9) and your right hand holding the rear handle (1). Do not start the product while handling it with one hand.
3. Push the lock-off button (2) forward with your right thumb, then fully depress the on/off switch (8) with your index fingers and hold it in this position. (Fig. 24)

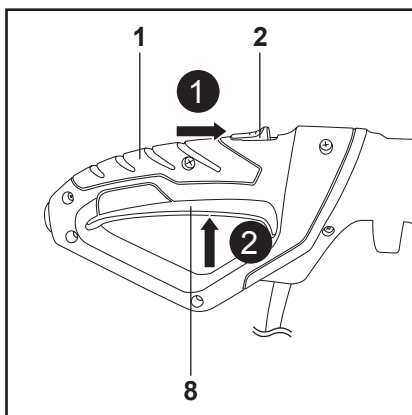



Fig. 24

4. Release the on/off switch (8) to switch the product off.



WARNING! The product will continue to work for some time even after the motor has been switched off! Wait until it comes to a complete stop before you put the product down!

Adjusting cutting head

1. Place the product on a stable, level surface with the angle adjusting button (11) facing upward. We recommend laying a nonflammable sheet under the product.
2. Press the angle adjusting button (11), meanwhile rotate the working head anticlockwise to the required working angle. Please note to align the mark  with the scale around the angle adjusting button (11); and please make sure you hear a “click” when do this adjustment or the angle adjusting button (11) bounces back, or else the working head is not locked well. (Fig. 25,26)

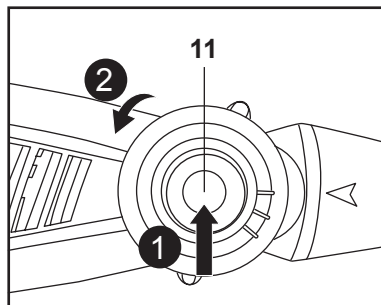

Fig. 25

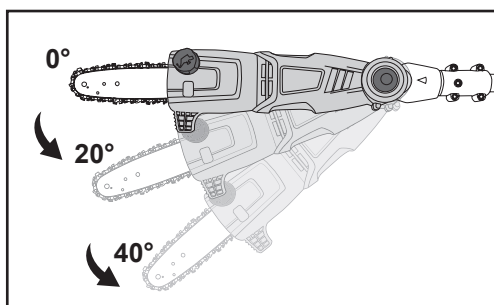

Fig. 26

Saw chain stop test



NOTE: Perform the following test before operating your product.

1. Hold the gripping surface (9) with the left hand, the rear handle (1) with your right hand.
2. Ensure the saw chain (14) does not come into contact anything when switching on.
3. Release the on/off switch (8) to switch the product off, the saw chain must come to a stop.



WARNING! If the saw chain shows any signs of moving stop the motor immediately! Wait for all moving parts to stop! Contact a qualified specialist to have a check!

General operation

1. Check the product, its power cord and plug as well as accessories for damage before each use. Do not use the product if it is damaged or shows wear.
2. Double check that accessories or application tools and the guide bar/ saw chain are properly fixed.
3. Check the chain oil level, refill if necessary.
4. Always hold the product on its handle(s)/gripping surface(s). Keep the handle(s)/gripping surface(s) dry and clean to ensure safe support.
5. Ensure that the air vents are always unobstructed and clear. Clean them if necessary with a soft brush. Blocked air vents may lead to overheating and damage the product.
6. Switch the product off immediately if you are disturbed while working by other people entering the working area. Always let the product come to complete stop before putting it down.
7. Do not overwork yourself. Take regular breaks to ensure you can concentrate on the work and have full control over the product.
8. Before switching the product on, check whether it has been assembled correctly and all the moving parts are running smoothly!
9. While working, ensure that the product does not strike hard objects, as this can cause damage.



WARNING! In some countries regulations define at what time of the day and on what special days products are allowed to be used and what restrictions apply! Ask your community for detailed information and observe the regulations in order to preserve a peaceful neighbourhood and avoid committing administrative offences!

Operating hours

Only operate the product at reasonable hours - not early in the morning, late at night or on weekends/public holidays when people might be disturbed. Inform yourself about local restrictions.

Pruning

Kickback



WARNING! Beware of kickback! Kickback can lead to dangerous loss of control of the product and result in serious or fatal injury to the operator or anyone standing close by! Always be alert because rotational kickback and pinch kickback are major product operational dangers and the leading cause of most accidents!



1. Kickback is the sudden backward/upward motion of the product, occurring when the chain (at the tip of the chain bar) comes in contact with a log or wood, or when the chain becomes jammed.
2. When kickback occurs the product reacts unpredictably and can cause severe injuries to the operator or bystanders.
3. With a basic understanding of 'kickback', the element of surprise can be reduced or eliminated. Sudden surprise contributes to the majority of accidents.
4. You should read all the safety warnings and user instructions carefully before attempting to operate this product.

To avoid kickback:

- Never work with a loose, widely stretched or heavily worn chain.
- Always use a low kickback chain.
- Ensure correct chain tension.
- Ensure the chain is sharpened correctly.
- Never work with the tip of the guide bar.
- Saw with the guide bar at a flat angle.
- Always hold the product firmly with both hands.

Pruning

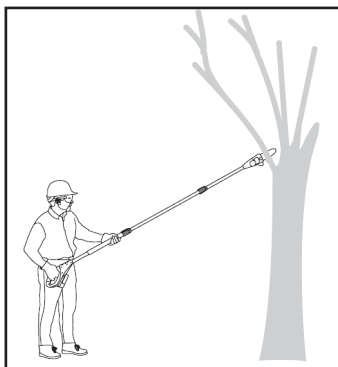

Fig. 27

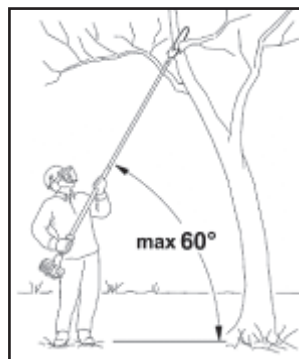

Fig. 28

1. Always hold the product firmly with both hands on gripping surface (9) and rear handle (1). Never operate this product using only one hand (Fig. 27).
2. Maintain a firm grip with your thumbs and fingers encircling the handles. A firm grip will help you reduce 'kickback' and maintain control of the product.
3. Always hold the product at an angle of not more than 60° from the horizontal level. Otherwise safe operation is not possible (Fig. 28).
4. Never stand directly under the limb you are sawing. Objects may fall different than expected. Always position yourself out of the path of falling limbs (Fig. 29).
5. Keep other persons away from cutting end of product and at a safe distance from the work area. Maintain a minimum distance of 10 m to bystanders (Fig. 30).



Fig. 29

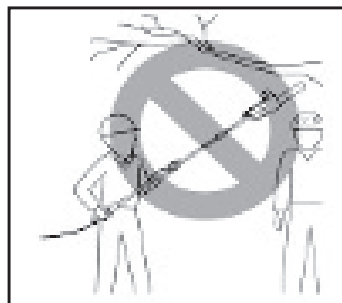

Fig. 30



WARNING! Never climb into a tree to prune! Do not stand on ladders, platforms, logs, or in any position which may cause you to lose your balance or control of the product! When pruning trees, it is important not to make the flush cut next to main limb or trunk until you have cut off the limb further out to reduce the weight! This prevents stripping the bark from the main member!

6. Never stand on a ladder or other type of unstable support while using the product. Insecure stand invites hazards (Fig. 31).



Fig. 31

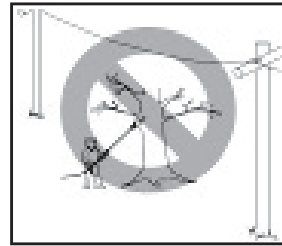

Fig. 32



WARNING! This product has not been designed to provide protection from electric shock in the event of contact with overhead electric lines! Therefore do not use product near cable, electric power or telephone lines. Keep a minimum distance of 10 m to all electric lines (Fig. 32).

7. Use the product only with secure footing. Hold the product at the right-hand side of your body. Regularly change the working position and include rest periods during operation.
8. Do not operate the product with arms fully extended or attempt to cut areas which are difficult to reach.
9. Keep a firm, steady pressure on the product while working with it. Do not try to force the product through the wood, let the cutting device do the work, using the gripping teeth to apply minimal leverage pressure.
10. Beware when reaching the end of the cut. The weight of the product may change unexpectedly as it cuts free from the wood. Accidents can occur to the legs and feet. Always remove the product from a wood cut while it is running.



NOTE: The chain must be running at full speed before it comes into contact with the wood.

Thin branches

Thin branches can be cut off with one single cut. To prevent the branch from slivering and buckling the branch should be cut off in several pieces (Fig. 33).

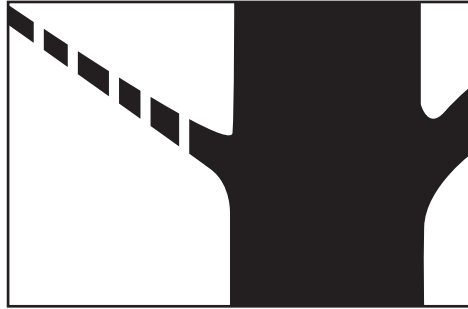

Fig. 33

Thick branches

When cutting off larger branches three cuts are necessary.



Fig. 34



Fig. 35



Fig. 36

1. First cut into the branch from below outside the place where you intend to cut off the branch. The cut should go from one third to halfway through the branch (Fig. 34).
2. Cut into the branch from the top outside at the same height the branch is sawn from top (Fig. 35).
3. Last, cut off the stump with one clean cut from top to bottom (Fig. 36).
4. You might want to seal the cut with a suitable compound.



NOTE: Remove the branches lying on the floor regularly to avoid stumbling hazards. Check the oil level regularly and fill up if necessary. Switch the power off and disconnect from power source when leaving the product.

After use

1. Switch the product off, disconnect it from the power supply and let it cool down.
2. Check, clean and store the product as described below.

The golden rules for care



WARNING! Always switch the product off, disconnect it from the power supply and let the product cool down before performing inspection, maintenance and cleaning work!



1. Keep the product clean. Remove debris from it after each use and before storage.
2. Regular and proper cleaning will help ensure safe use and prolong the life of the product.
3. Inspect the product before each use for worn and damaged parts. Do not operate it if you find broken and worn parts.



WARNING! Only perform repairs and maintenance work according to these instructions! All further works must be performed by a qualified specialist!

General cleaning

1. Make sure the product is switched off, cooled down and disconnected from the power supply.
2. Clean the product with a slightly damp cloth and mild soap. Use a brush for areas that are hard to reach.
3. In particular clean the air vents (21) after every use with a cloth and brush.
4. Remove stubborn dirt with high pressure air (max. 3 bar).



NOTE: Do not use chemical, alkaline, abrasive or other aggressive detergents or disinfectants to clean this product as they might be harmful to its surfaces.

5. Check for any damage and wear. Repair damages in accordance with this instruction manual or take it to an authorised service centre before using the product again.

Sprocket wheel



NOTE: It is not necessary to remove the saw chain (14) to lubricate the sprocket wheel. Lubrication can be done on the job.

1. Clean the sprocket wheel (15).
2. Using a disposable lube gun, insert the needle nose into the lubrication hole (Fig. 37, A) and inject grease until it appears at the outside edge of the sprocket (15) (Fig. 37).

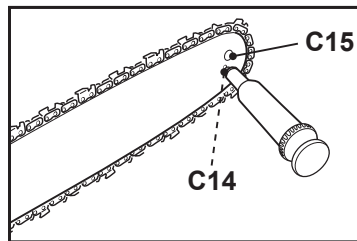

Fig. 37

3. Rotate the saw chain (14) by hand. Repeat the lubrication procedure until the entire sprocket (15) has been greased.

Guide bar and saw chain maintenance

Guide bar

Most guide bar problems can be prevented merely by keeping the product well maintained. Incorrect filling and non-standard cutter and depth gauge settings are the causes of most guide bar problems, primarily resulting in uneven bar wear. As the bar wears unevenly, the rails widen, which may cause the chain to clatter and make it difficult to complete straight cuts. If the guide bar is insufficiently lubricated and the product is operated with a saw chain which is too tight, this will contribute to rapid bar wear. To help minimise bar wear, maintenance of the guide bar as well as the saw chain is recommended.

1. Disassemble the guide bar and saw chain in reversed order from assembly.
2. Check the oiling port (25) for clogging and clean if necessary to ensure proper lubrication of the guide bar and saw chain during operation. Use a soft wire small enough to insert into the oil discharge hole (Fig. 38).

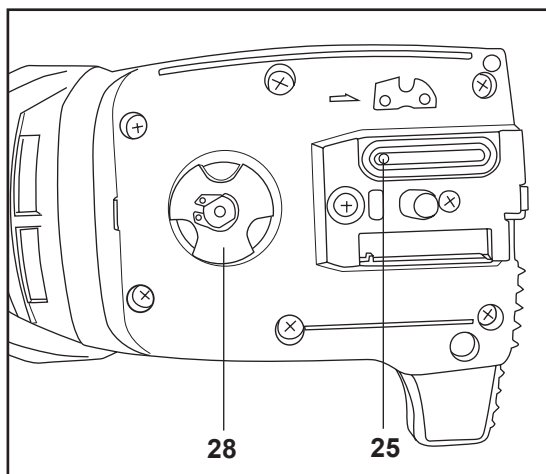

Fig. 38



NOTE: The condition of the oil passages can be easily checked. If the passages are clear, the chain will automatically give off a spray of oil within seconds of the product starting. Your product is equipped with an automatic oiling system.

3. Check the drive sprocket (28). If it is worn or damaged due to strain, have it replaced by an authorised service agent.
4. Clear residue from the rails on the guide bar (13) by using a screwdriver, putty knife, wire brush or other similar tool. This will keep the oil passages open to provide proper lubrication to the bar (13) and chain (14) (Fig. 39).

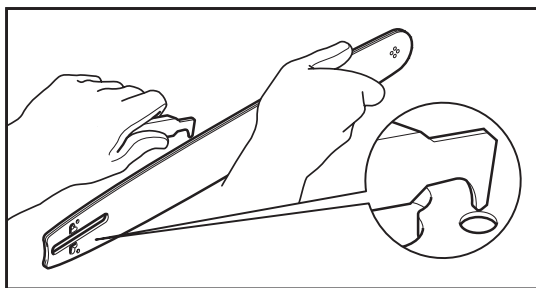

Fig. 39

5. Check the guide bar 'rail' for wear: Hold a ruler (straight edge) against the side of the guide bar and 'cutter side plates'. If there is a gap between the ruler and guide bar the guide bar 'rail' is normal. If there is no gap (ruler flush against the side of the guide bar) the guide bar 'rail' is worn and needs to be replaced with a new one of the same type (Fig. 40).

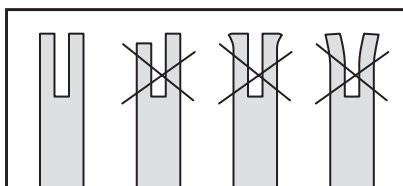

Fig. 40

6. Check the saw chain for possible wear and damages. Replace it with a new one if required. Experienced user can sharpen a dull saw chain (see section “Saw chain sharpening” below).
7. Refit the saw chain (14) and the guide bar (13) as described under “Assembly”.

Saw chain sharpening



NOTE: Never saw with a blunt chain. The saw chain is blunt if you have to push the product into the tree and the chips are very small.

1. Have the saw chain (14) sharpened professionally at an authorised service centre or sharpen the chain yourself by using a proper sharpening kit. Also observe the sharpening instructions supplied with the sharpening kit.



WARNING! Only sharpen the saw chain yourself if you are trained and have experience! Use proper tools to sharpen the saw chain!

2. The height difference between the tooth and the ridge is the cutting depth. When sharpening the saw chain (14) you have to consider the following points (Fig. 41).
 - File angle
 - Cutting angle
 - File position
 - Diameter of round file
 - File depth

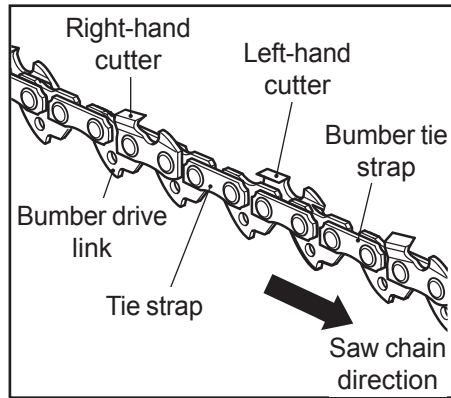

Fig. 41

3. To sharpen the chain proceed as follows:
 - Use protective gloves.
 - Ensure the chain is correctly tensioned.
 - Engage the chain brake to lock the chain on the bar.
4. Use a chain file, whose diameter is 1.1 times the cutting tooth depth. Make sure 20 % of the file diameter is above the cutter's top plate.



NOTE: A file guide is available from most reputable tool merchants and is the easiest way to hold the file at the correct position.

5. File at an angle perpendicular to the bar, and at an angle of 25° to the direction of travel (Fig. 42).

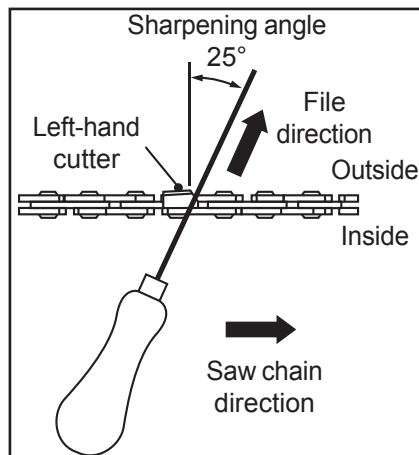

Fig. 42

6. File each tooth from the inside towards outside only. File one side of the chain first than turn the saw around and repeat the process.
7. Sharpen each tooth equally by using the same number of strokes.
8. Keep all cutter lengths equal. Check the safety depth gauge height every 5 sharpenings. If the depth gauges are also trimmed it is essential that the original profile be restored.
9. Use a depth gauge measuring instrument to check the height of the depth gauge. Depth gauge measuring jigs are available from most reputable tool merchants (Fig. 43).

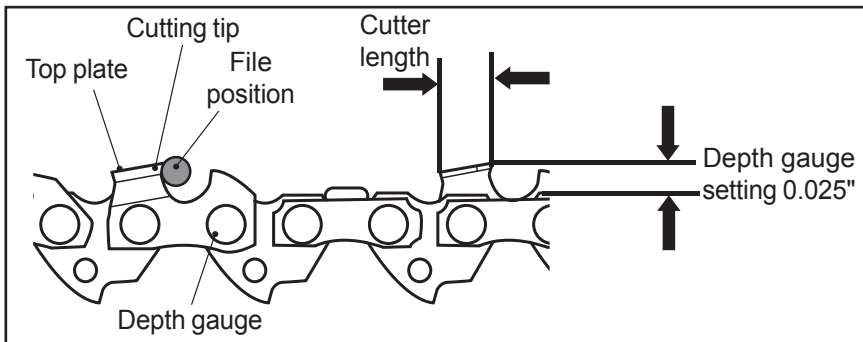

Fig. 43

Spare parts/Replacement parts

The following parts of this product may be replaced by the consumer. Spare parts are available at an authorised dealer or through our customer service.

Description	Model no. or Specification
Saw chain	Oregon 91PJ033X
Guide bar	Oregon 546649

Power cord

1. If the power cord is damaged, it must be replaced by the manufacturer, its service agent or similarly qualified persons in order to avoid a safety hazard.

Plug replacement (for UK only)

If you need to replace the fitted plug, then follow the instructions below.

IMPORTANT: The wires in the mains lead are coloured in accordance with the following code: Blue - Neutral Brown - Live

As the colours of the wire in the mains lead of this product may not correspond with the coloured marking identifying the terminals in your plug, proceed as follows. The wire, which is coloured blue, must be connected to the terminal, which is marked with N or coloured black. The wire, which is coloured brown, must be connected to the terminal, which is marked L or coloured red.

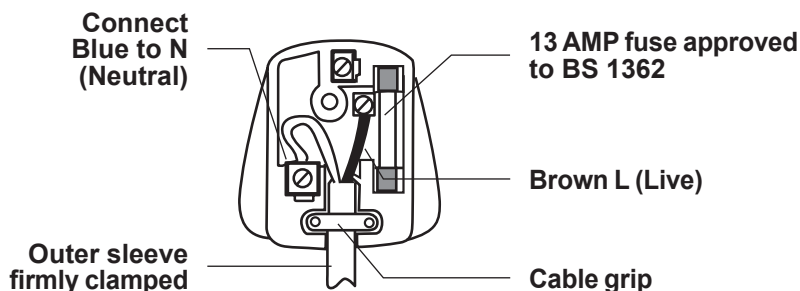

WARNING! Never connect live or neutral wires to the earth terminal of the plug.

Only fit an approved 13 Amp BS 1363 or BS 1363/A plug and the correctly rated fuse. If in doubt, consult a qualified electrician.



NOTE: If a moulded plug is fitted and has to be removed take great care in disposing of the plug and severed cable, it must be destroyed to prevent engaging into a socket.

Repair

This product does not contain any parts that can be repaired by the consumer. Contact a qualified specialist to have it checked and repaired.

Storage

1. Clean the product as described above.
2. Store the product and its accessories in a dry, frost-free, well-ventilated place.

3. Always store the product in a place that is inaccessible to children. The ideal storage temperature is between 10 and 30°C.
4. We recommend using the suitable package for storage or covering the product with a suitable cloth or enclosure to protect it against dust.
5. Empty the tank if you are not going to use the product for an extended period of time (more than 3 months) and before storing it for the winter.

Transportation

1. Switch the product off and disconnect it from power supply before transporting it anywhere.
2. Attach transportation guards, if applicable.
3. Always carry the product on its handles.
4. Protect the product from any heavy impact or strong vibrations which may occur during transportation in vehicles.
5. Secure the product to prevent it from slipping or falling over.

Troubleshooting

Suspected malfunctions are often due to causes that the users can fix themselves. Therefore check the product using this section. In most cases the problem can be solved quickly.



WARNING! Only perform the steps described within these instructions! All further inspection, maintenance and repair work must be performed by an authorised service centre or a similarly qualified specialist if you cannot solve the problem yourself!

Problem	Possible cause	Solution
1. Product does not start	1.1. Not connected to power supply	1.1. Connect to power supply
	1.2. Power cord or plug is defective	1.2. Check by a specialist electrician
	1.3. Other electrical defect to the product	1.3. Check by a specialist electrician

Problem	Possible cause	Solution
2. Product does not reach full power	2.1. Extension cord not suitable for operation with this product	2.1. Use a proper extension cord
	2.2. Power source (e.g. generator) has too low voltage	2.2. Connect to another power source
	2.3. Air vents are blocked	2.3. Clean the air vents
3. Unsatisfactory cutting performance	3.1. Saw chain not tensioned properly	3.1. Tension properly
	3.2. Saw chain is dull/damaged	3.2. Sharpen or replace the saw chain
4. Excessive vibration/noise	4.1. Saw chain is dull/damaged	4.1. Sharpen or replace the saw chain
	4.2. Bolts/nuts are loosen	4.2. Tighten bolts/nuts

Recycling and disposal



The product comes in a package that protects it against damage during shipping. Keep the package until you are sure that all parts have been delivered and the product is function properly. Recycle the package afterwards.

Lubricant, oil and used oil as well as objects contaminated with oil, e.g. cleaning cloths; do not belong with household waste. Dispose of oil- contaminated items in accordance with the local guidelines and hand them in at recycling centres.

Old products are potentially recyclable under WEEE and do not, therefore, belong in your household rubbish. You are requested to assist us and our contribution to saving resources and protecting the environment by handing in this appliance at an equipped collection centre (if there is one available).

Technical specifications

General

- > **Rated voltage** : 220 - 240 V~, 50 Hz
- > **Rated input** : 750 W
- > **Rated no load speed n_0** : 5000 min⁻¹
- > **Cutting angel** : 3 settings, 0°-20°-40°
- > **Oil tank volume** : 90 cm³ (ml)
- > **Protection class** : II / □
- > **Protection degree** : IPX0
- > **Weight assembled** : approx. 3.7 kg
- > **Dimension (L x W x H)** : 1985(2745) x 135 x 140 mm

Chain and guide bar

- > **Chain type** : 91PJ033X Oregon
- > **Guide bar type** : 546649 Oregon
- > **Guide bar length** : 203 (8")
- > **Max. cutting length** : 180 mm
- > **Chain pitch** : 9.525mm (0.375")
- > **Chain gauge** : 1.27 mm (0.050")
- > **Drive sprocket** : 6 teeth x 30 mm
- > **Maximum chain speed** : 9.2 m/s

Sound level according to EN ISO 3744, ISO 22868 and 2000/14/EC

- > **Sound pressure level, L_{pa}** : 88.7 dB(A)
- > **Uncertainty K** : 3 dB(A)
- > **Sound power level, L_{WA}** : 100.3 dB(A)
- > **Uncertainty K** : 3 dB(A)
- > **Guaranteed sound power level, L_{WA}** : 104 dB(A)

Hand arm vibration according to ISO 22867

- > **Main handle, a_h** : 1.353 m/s²
- > **Auxiliary handle, a_h** : 2.134 m/s²
- > **Uncertainty K** : 1.5 m/s²

Wear hearing protection, especially when sound pressure is over 80 dB(A).

The declared vibration value has been measured in accordance with a standard test method and may be used for comparing one product with another. The declared vibration value may also be used to evaluate the exposure for the user caused by vibration in advance.



WARNING! Depending on the actual use of the product the vibration values can differ from the declared total! Adopt proper measures to protect yourself against vibration exposures. Take the whole work process including times the product is running under no load or switched off into consideration. Proper measures include among others regular maintenance and care of the product and application tools, keeping hands warm, periodical breaks and proper planning of work processes

Guarantee

We take special care to select high quality materials and use manufacturing techniques that allow us to create products incorporating design and durability. This product has a manufacturer's guarantee of 2 years against manufacturing defects, from the date of purchase (if bought in store) or date of delivery (if bought online), at no additional cost for normal (non-professional or commercial) household use.

To make a claim under this guarantee, you must present your proof of purchase (such as a sales receipt, purchase invoice or other evidence admissible under applicable law), please keep your proof of purchase in a safe place. For this guarantee to apply, the product you purchased must be new, it will not apply to second hand or display products. Unless stated otherwise by applicable law, any replacement product issued under this guarantee will only be guaranteed until expiry of the original period guarantee period.

This guarantee covers product failures and malfunctions provided the product was used for the purpose for which it is intended and subject to installation, cleaning, care and maintenance in accordance with the information contained in these terms and conditions, in the user manual and standard practice, provided that standard practice does not conflict with the user manual.

This guarantee does not cover defects and damage caused by normal wear and tear or damage that could be the result of improper use, faulty installation or assembly, neglect, accident, misuse, or modification of the product. Unless stated otherwise by applicable law, this guarantee will not cover, in any case, ancillary costs (shipping, movement, costs of uninstalling and reinstalling, labour etc), or direct and indirect damage.

This guarantee does not cover defects and damage caused by or resulting from:

- Normal wear and tear
- Overload, misuse or neglect
- Repairs attempted by anyone other than an authorised agent
- Cosmetic damage

- Damage caused by foreign objects, substances or accidents
- Accidental damage or modification
- Failure to follow manufacturer's guidelines
- Loss of use of the goods

If this product is defective, we will, within a reasonable time, repair, replace or provide spare parts.

Rights under this guarantee are enforceable in the country in which you purchased this product. Guarantee related queries should be addressed to the store you purchased this product from.

The guarantee is in addition to and does not affect your statutory rights.





**IMPORTANT - RETAIN THIS INFORMATION FOR
FUTURE REFERENCE: READ CAREFULLY**

Customer care and technical helpline

A better way to repair your tools

Kingfisher takes special care in creating high-quality garden power tools that are designed to last. But if a fault develops with your garden power tool and you need to claim under the guarantee, the Customer Care and Technical Helpline can support with technical assistance or if required, arrange a free courier collection from your home, assess your garden power tool for fault, repair it, and return it.

Deciding to repair your product rather than buying a replacement and adding to the mountain of waste is a more sustainable choice and you will be doing your bit for the environment.

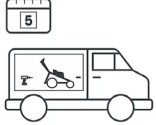
How does it work?				
				
Step 1	Step 2	Step 3	Step 4	Step 5
Find your proof of purchase and get in touch with the Customer Care and Technical Helpline.	Chat to them about the problem with your tool.	They will provide technical and user advice or alternatively arrange a courier collection from your home.*	The team will assess and test and if necessary, repair your product back to full working order.	Your repaired tool will be returned to you via courier within 5 working days*.

Get in touch

If you need help or more information, please contact the Customer Care and Technical Helpline:

UK: 0800 0789647

Eire: 1800 932226

Opening hours are Monday – Friday, 8am-5pm

Availability of spare parts

Contact the customer service helpline for assistance or visit www.kingfisherspares.com

For assistance contact the customer services helpline:

UK 0800 0789647 uk@Kingfisherservice.com

EIRE 1800 932226 eire@kingfisherservice.com

Further information about this product can also be found at:

www.kingfisher.com/products

Manufacturer:

UK Manufacturer:

Kingfisher International Products Limited
1 Paddington Square, London, W2 1GG,
United Kingdom

EU Manufacturer:

Kingfisher International Products B.V.
Rapenburgerstraat 175E 1011 VM Amsterdam
 The Netherlands

www.diy.com
www.screwfix.com
www.screwfix.ie

To view instruction manuals online,
visit www.kingfisher.com/products